

TECHNICAL DATA SHEET

SOLENOID VALVE DIRECT ACTING

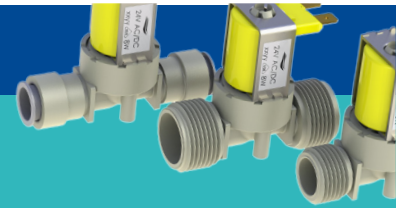

DESCRIPTION

An extensive range of direct acting solenoid valves to provide safe conveyance, distribution and control of water services in a wide range of applications. The key attributes are:

- Robust construction and long service life
- Wide selection of standard port connections
- Modular platform to facilitate client specific port options

APPLICATION

- Drinks dispense machines
- Low pressure appliances

GENERAL PERFORMANCE DATA

VOLTAGE:	220 - 240 vac, 110 - 120 vac, 24, 12V AC/DC
FREQUENCY:	50 - 60 Hz & DC
POWER DRAW:	6 Watts (230vac) & 9 Watts (24Vdc)
COIL INSULATION:	Class F (140°C Operating Temperature)
INSULATION:	Class II. Fully double insulated. No Earth required.
AMBIENT TEMPERATURE:	60°C maximum
MEDIUM:	Potable water, 90°C maximum
DUTY CYCLE 100%:	Tu 60°C (ambient), Tm 25°C (Cold Water)
DUTY CYCLE:	3min ON/5 Min Off Tu 60°C (ambient), Tm 90°C (Hot Water)
OPERATING PRESSURE:	0 - 0.2 Bar
EMC:	Fully compliant
TERMINALS:	Two 6.35 x 0.8 mm male tab terminals

COIL OPTIONS

Solenoid coils are supplied with the standard 6.5 x 0.8 terminals; options are available for RAST 5 and RAST 2.5 subject to minimum order volumes.

COLOUR	(V)	VOLTAGE TOLERANCE	FREQUENCY (HZ)	CURRENT (AMPS)	POWER (W)	RESISTANCE (Ω)	DUTY CYCLE
BROWN	230	10	50-60	0.035	5.8	3820	100%
BEIGE	230	10	50-60	0.03	5.0	4060	100%
BLACK	110	10	50-60	0.45	4.0	1180	100%
YELLOW	24	10	50-60	0.19	2.78	60	100%
YELLOW	24	10	DC	0.39	9.4	60	3min on, 5min off
GREY	12	10	50-60	0.38	4.5	14.5	100%
GREY	12	10	DC	0.82	9.0	14.5	3min on, 5min off

TECHNICAL DATA SHEET

SOLENOID VALVE DIRECT ACTING

SCHEMATIC DIAGRAM

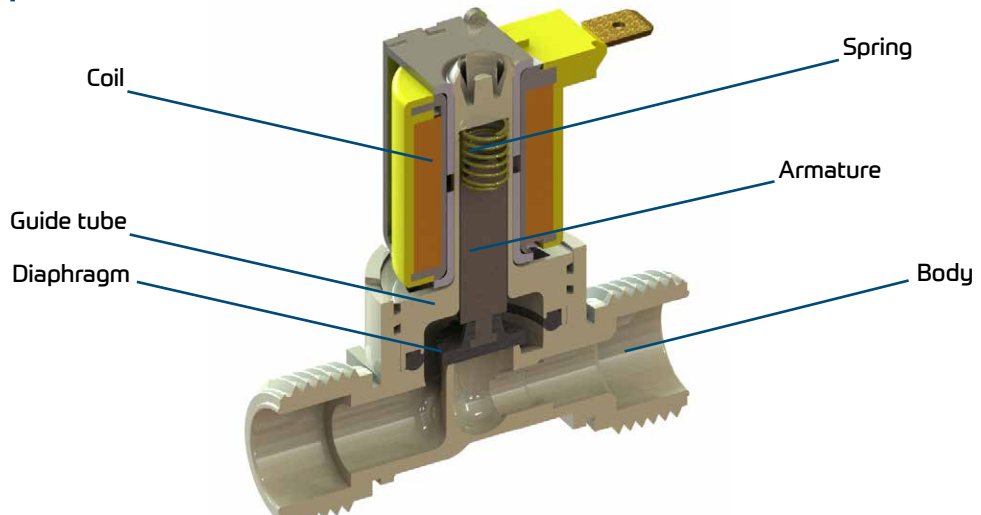

GENERAL CONSTRUCTION DATA

COMPONENT	MATERIAL
BODY	NYLON PA 6.6 30% Glass Filled
GUIDE TYPE	NYLON PA 6.6 30% Glass Filled
SPRING	AISI 316 stainless steel
ARMATURE	Stainless Steel Z6CDF18.2 (ASTM XM 34)
DIAPHRAGM AND ARMATURE TIP	EPDM
COIL BOBBIN	Nylon PA 6.6 heat stabilised
COIL ENCAPSULATION	Nylon PA 6 heat stabilised
MAGNETIC CIRCUIT	Mild Steel 1.2 Galvanised bichromated
MOUNTING BRACKET	Mild Steel 1.2 Galvanised bichromated

CHEMICAL RESISTANCE

If using strong or aggressive chemicals please verify the material compatibility from the list above. Chemical resistance information is available at: www.hydraelectric.com/h/chemical-resistance.

MOUNTING

The valves can be mounted via 2 self-tapping screws from the underside of the main body. Note: Avoid penetrating the diaphragm chamber with excess screw length.

INSTALLATION REQUIREMENTS

OPERATING PRESSURE:	Maximum 0.2bar
INLET MATING CONNECTION:	Maximum torque setting 4.0 Nm
WATER QUALITY:	Solenoid valves are designed for use on potable clean water systems, excessive particulates can cause failure. Avoid direct connection to hot water boilers which may cause excess build up of calcium deposits
INLET FILTER:	0.4 mesh filter must be fitted up stream of the valve; failure to use a filter upstream of diaphragm can cause failure
SERVICE LIFE:	50,000 operations under hot and cold water conditions, service life will vary according to local water conditions and temperature

TECHNICAL DATA SHEET

SOLENOID VALVE DIRECT ACTING

PORT CONNECTIONS

	SINGLE VALVE 180° BODY	
	INLET	OUTLET
	3/4BSP	3/4BSP
	1/2BSP	1/2BSP
	15mm Compression (1/2BSP)	15mm Compression (1/2BSP)
3/8BSP	3/8BSP	

	SINGLE VALVE 180° BODY & JOHN GUEST COLLET SYSTEM	
	INLET	OUTLET
	3/8 Push Fit	3/8 Push Fit
	5/16 Push Fit	5/16 Push Fit
	10mm Push Fit	10mm Push Fit
8mm Push Fit	8mm Push Fit	

	SINGLE VALVE 180° BODY
	<p>Ports can be customised to specific applications allowing more effective integration into the client equipment. The mould tool construction is modular allowing for the inlet and outlet ports to be customised.</p>

STANDARDS

The Solenoid Valves range is subjected to compliance testing and approval to following standards:

- ACS: Attestation de conformité sanitaire
- RoHS: European Directive 2002/95/EC
- UK: BS6920

TECHNICAL ASSISTANCE

Please contact our Sales or Technical Support team on 0044 (0) 1932 334200, or visit our website www.hydraelectric.com