

TECHNICAL DATA SHEET

SOLENOID VALVE

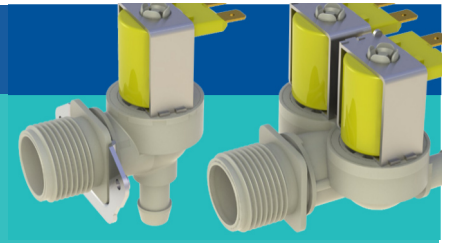

DESCRIPTION

An extensive range of pilot operated solenoid valves to provide safe conveyance, distribution and control of water services in a wide range of applications. The key attributes are:

- **European & US approval for both electrical and potable water compliance**
- **Robust construction and long service life**
- **Wide selection of standard port connections.**

APPLICATION

- **Drinks dispense machines**
- **Shower and bath systems**
- **Glass and dish washers equipment**
- **Automatic taps**

GENERAL PERFORMANCE DATA

VOLTAGE:	230V AC, 120V AC, 24V AC/DC, 12V AC/DC
FREQUENCY:	50 - 60 Hz & DC
POWER DRAW:	7 Watts (230V), 7 Watts (120V) & 4.6 Watts (24Vdc)
COIL INSULATION:	Class F (140°C Operating Temperature)
INSULATION:	Class II. Fully double insulated. No Earth required.
AMBIENT TEMPERATURE:	60°C maximum
MEDIUM:	Potable water, 90°C maximum
DUTY CYCLE 100%:	Tu 60°C (ambient), Tm 25°C (Cold Water)
DUTY CYCLE:	3min ON/5 Min Off Tu 60°C (ambient), Tm 90°C (Hot Water)
OPERATING PRESSURE:	0.2 to 10 Bar
FLOW REGULATOR:	0.5 - 17 litres/minute
EMC:	Fully compliant
APPROVALS:	EN 60 730-2-8, WRAS
TERMINALS:	Two 6.35 x 0.8 mm male tab terminals

COIL OPTIONS

Solenoid coils are supplied with the standard 6.5 x 0.8 terminals; options are available for RAST 5 and RAST 2.5 subject to minimum order volumes.

COLOUR	(V)	VOLTAGE TOLERANCE	FREQUENCY (HZ)	CURRENT [AMPS]	POWER [W]	RESISTANCE [Ω]	DUTY CYCLE
BROWN	230	10	50-60	0.035	5.8	3820	100%
BEIGE	230	220-240	50-60	0.03	7.0	4060	100%
BLACK	110	110-120	50-60	0.45	7.0	1180	100%
YELLOW	24	10	50-60	0.19	4.6	60	100%
YELLOW	24	10	DC	0.39	9.4	60	3min on, 5min off
GREY	12	10	50-60	0.38	4.5	14.5	100%
GREY	12	10	DC	0.82	9.0	14.5	3min on, 5min off
GREEN	12	10	DC	0.2	2.3	56	100%

TECHNICAL DATA SHEET

SOLENOID VALVE RANGE

SCHEMATIC DIAGRAM

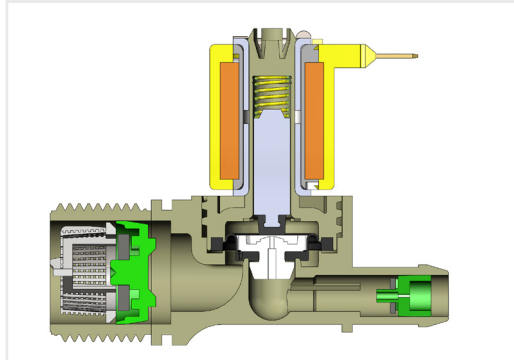

GENERAL CONSTRUCTION DATA

COMPONENT	MATERIAL
BODY	NYLON PA 6.6 30% Glass Filled
GUIDE TUBE	NYLON PA 6.6 30% Glass Filled
SPRING	AISI 316 stainless steel
ARMATURE	Stainless Steel Z6CDF18.2 (ASTM XM 34)
DIAPHRAGM, FLOW REGULATOR AND ARMATURE TIP	EPDM or NBR
FILTER	Polyacetal
FLOW REGULATOR HOUSING	Polyacetal
NON RETURN VALVE CARTRIDGE	Polyacetal
COIL BOBBIN	Nylon PA 6.6 heat stabilised
COIL ENCAPSULATION	Nylon PA 6 heat stabilised
MAGNETIC CIRCUIT	Mild Steel 1.2 Galvanised bichromated
MOUNTING BRACKET	Mild Steel 1.2 Galvanised bichromated

CHEMICAL RESISTANCE

Please verify valve material if using strong or aggressive chemicals in its application. Chemical resistance information is available at <http://www.hydraelectric.com/h/chemical-resistance>.

GENERAL INSTALLATION REQUIREMENTS

MINIMUM OPERATING PRESSURE:	0.2 Bar, for effective closure of diaphragm to valve seat
MINIMUM DIFFERENTIAL PRESSURE:	0.2 Bar, min pressure differential between inlet and outlet of valve
INLET MATING CONNECTION:	Maximum torque setting 4.0 Nm
WATER QUALITY:	Solenoid valves are designed for use on potable clean water systems, excessive particulates can cause failure. Avoid direct connection to hot water boilers which may cause excess build up of calcium deposits
INLET FILTER:	0.4 mesh filter must be fitted up stream of the valve; failure to use a filter upstream of diaphragm can cause failure
SERVICE LIFE:	50,000 operations under hot and cold water conditions, service life will vary according to local water conditions and temperature. Mean Time before Failure (MTBF) has been tested with first defects after 450,000 cycles, under following conditions, Water temperature 30°C, Ambient 25°C, Dynamic Pressure 5 Bar, Static Closing pressure 10 Bar, Duty Cycle 3min ON, 3min OFF

TECHNICAL DATA SHEET

SOLENOID VALVE RANGE

MOUNTING

All 3/4BSP inlet ports are provided with the option for M4 steel Mounting Brackets.

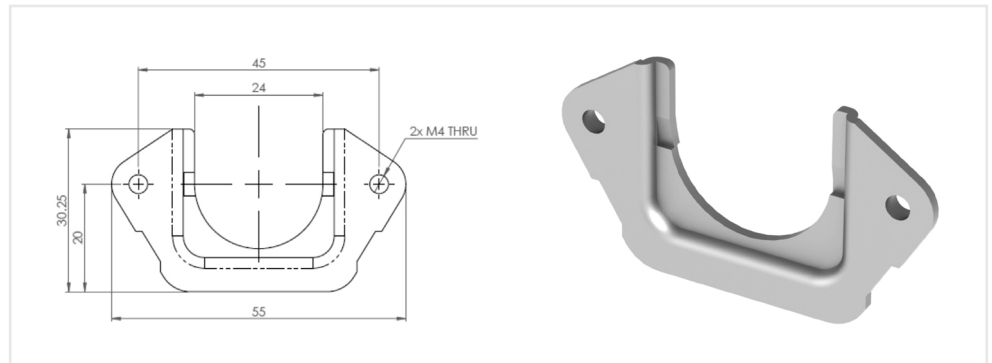

FLOW

The graph represents typical flow curve for solenoid valve without restriction on the outlet and dynamic inlet pressure between 0 and 5 Bar.

Note:

*Maximum flow rate is 20 lit/min.
above this value the valve may fail to
close after the coil is de-energised.*

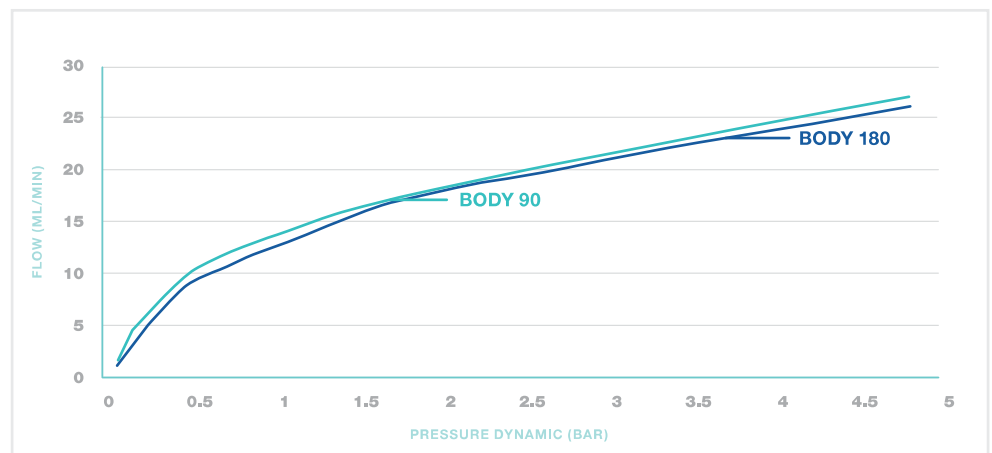

TECHNICAL DATA SHEET

SOLENOID VALVE RANGE

CHEMICAL RESISTANCE

A flow regulator can be fitted to the inlet and outlet ports to provide constant flow with an inlet pressure range of 1 to 10bar.

The flow regulator is composed of a plastic housing with studs onto which a rubber seal is located. Flow is controlled by pressure acting on the washer thus restricting the gap between the stud and water passage.

INLET FLOW REGULATORS

COLOUR	FLOW L/MIN	FLOW US GAL/MIN	TOLERANCE (%)
BROWN	5	1.32	15
DARK BLUE	6	1.58	15
PALE ORANGE	8	2.11	15
LIGHT BLUE	9	2.38	15
WHITE	10	2.64	15
GREEN	11	2.9	15
GREY	12	3.17	15
PINK	17	4.49	25

OUTLET FLOW REGULATORS

COLOUR	FLOW L/MIN	FLOW US GAL/MIN	TOLERANCE (%)
YELLOW	0.5	0.13	30
BLUE	1.2	0.32	25
PALE GREEN	2	0.53	25
BROWN	2.5	0.66	25
VIOLET	3.3	0.87	25
ORANGE	3.8	1	25

NON RETURN VALVES

Pilot operated solenoid valves have a low resistance to back siphoning; a spring loaded resilient non return cartridge (WRAS Approved) can be fitted to the 3/4BSP inlet port variants only.

STANDARDS

The Solenoid Valves range is subjected to compliance testing and approval to following standards,

- **WRAS: Water Research Advisory Scheme (Hot & Cold Water)**
- **ENEC: European Safety Mark EN 60 730-2-8**
- **UL & CSA Underwriters Laboratories Inc**
- **RoHS: European Directive 2002/95/EC**

TECHNICAL ASSISTANCE

Please contact our Sales or Technical Support team on **+386 (0) 7 30 53 162** , or visit our website www.eki.si